

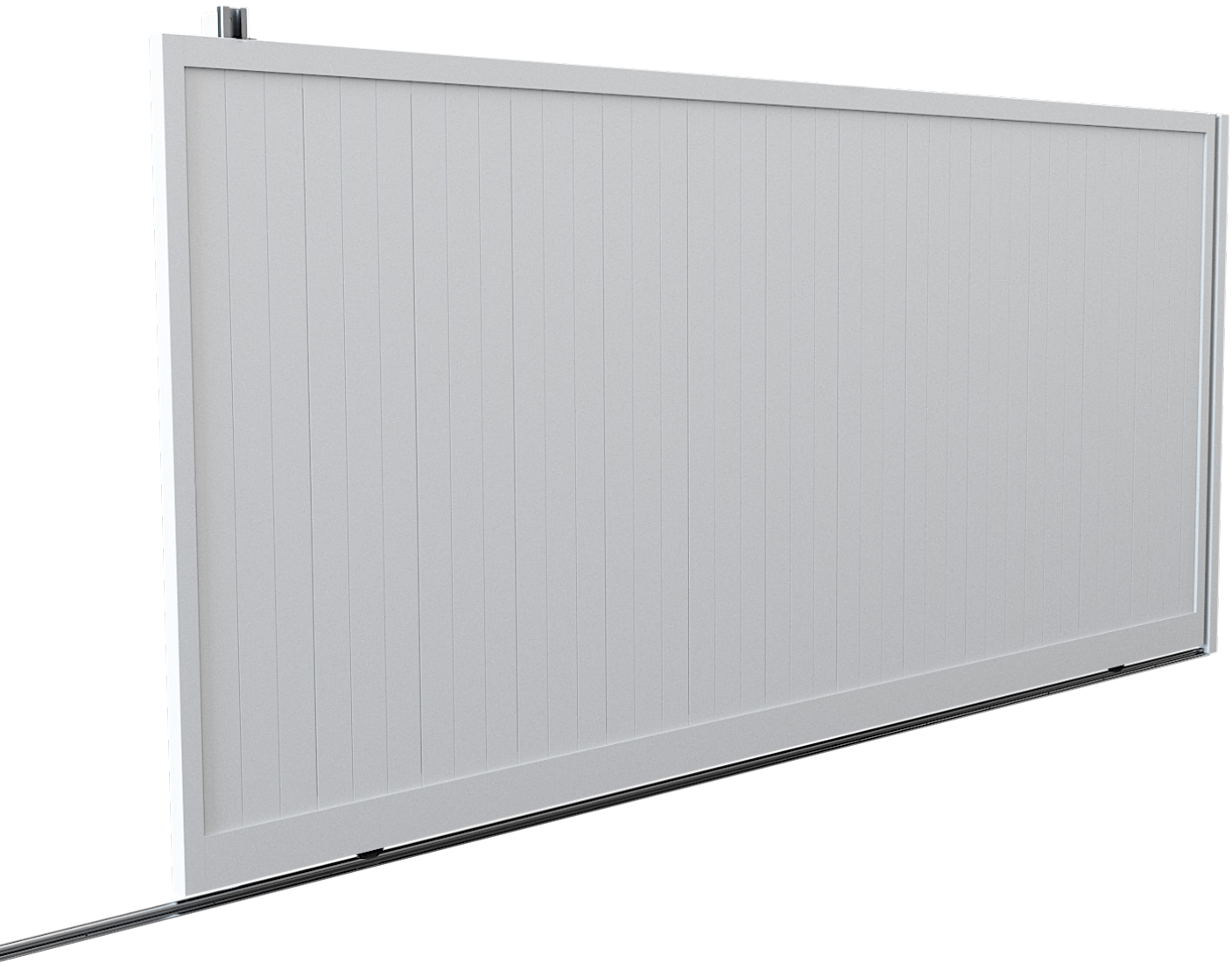

QUICKSCREEN SLIDING GATE
HAMPTONS FULL PRIVACY
SLIDING GATE

FABRICATION
OVERVIEW





Infill Panel

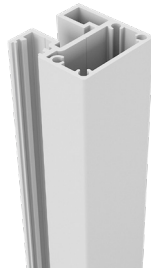

Gate Side Frame



Gate Screw Cover

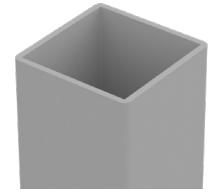

65x65 Steel Post

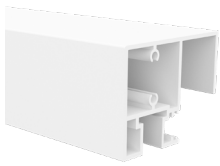

65mm Top Rail



Bottom Rail



Gate Top Cap



Gate Infill for PVC Panels

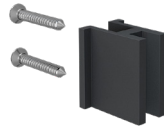

Joiner Blocks and Screws for Top/Bottom Rails



Panhead Screws



Slide Guide

OR

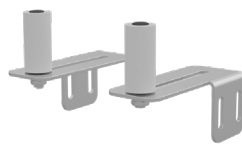

Roller Guides
(Left and Right - fixings not included)



Gate Wheel



Wheel Clamping Set



Track Pins

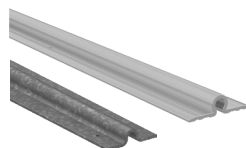

Sliding Gate Track
Steel or Aluminium



U Catch or F Catch
Fixings not included



Gate Stop
Fixings not included

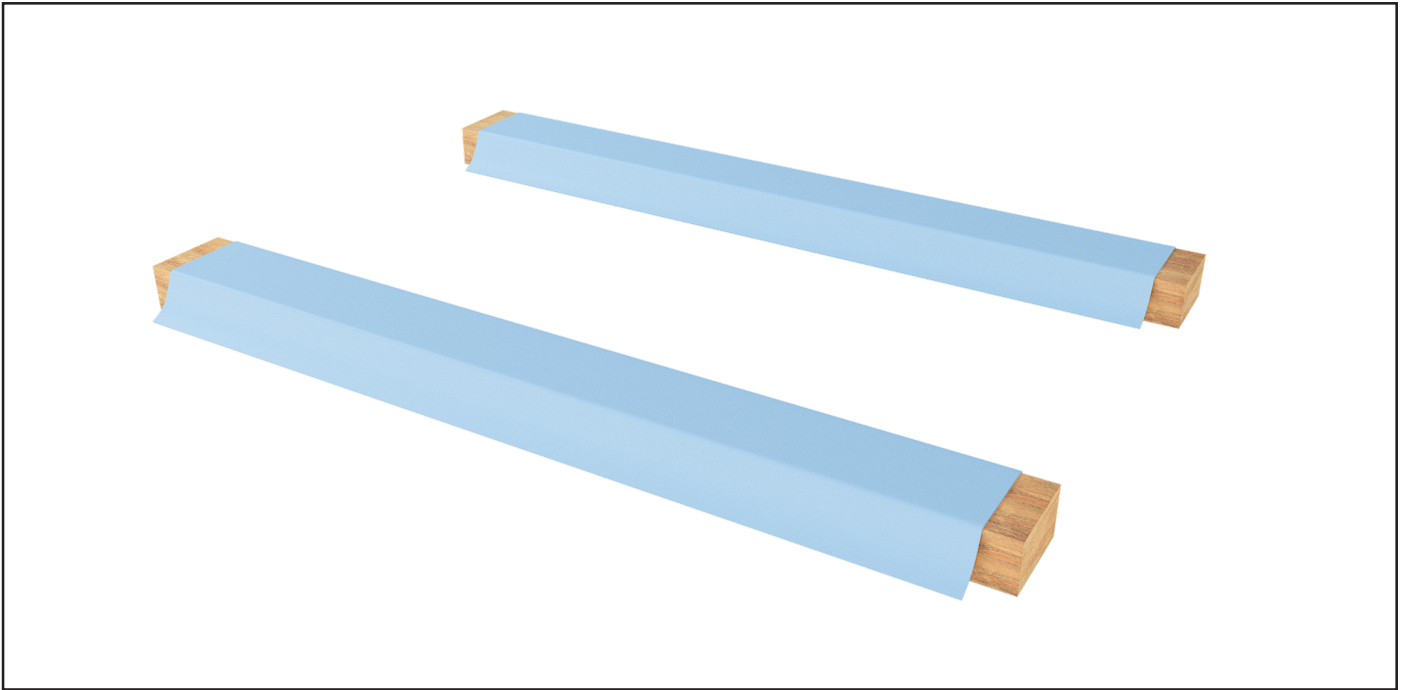

1 Set up the gate fabrication area on a flat, protected surface or padded bearers

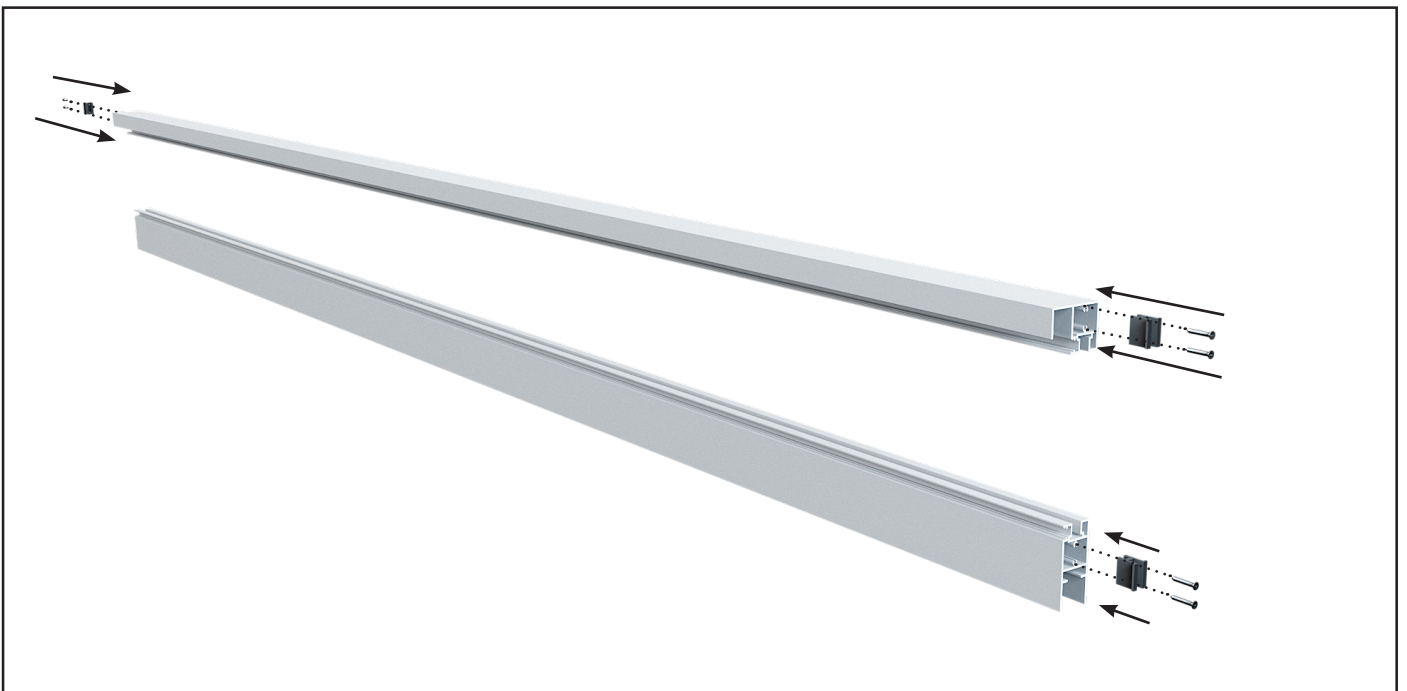

2 Attach the Joiner Blocks to both ends of the Top and one end of the Bottom Rail with two screws per Joiner block using a Phillips head #3 driver bit on a low-torque/low-speed cordless drill setting.

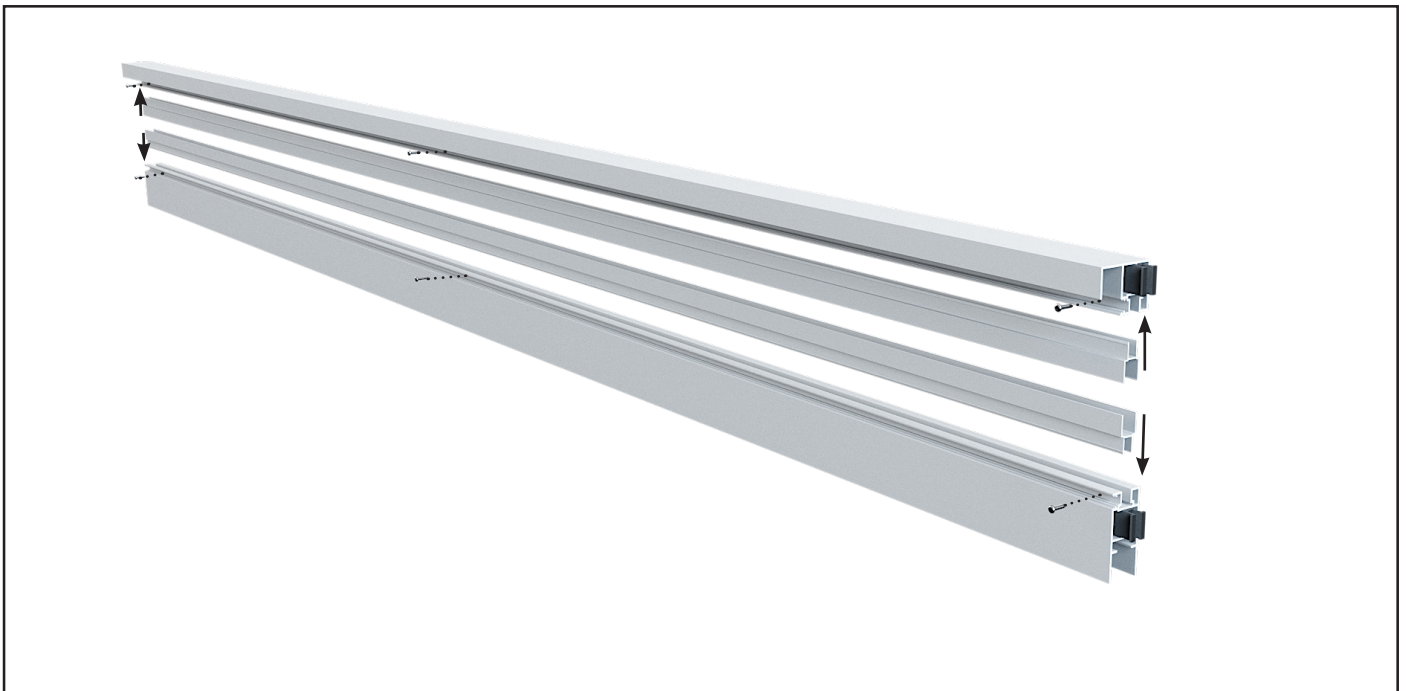

3 Insert Gate Infills for PVC Panels into the top and bottom rails and secure with three self-drilling wafer screws per Gate Infill within the screw channel.

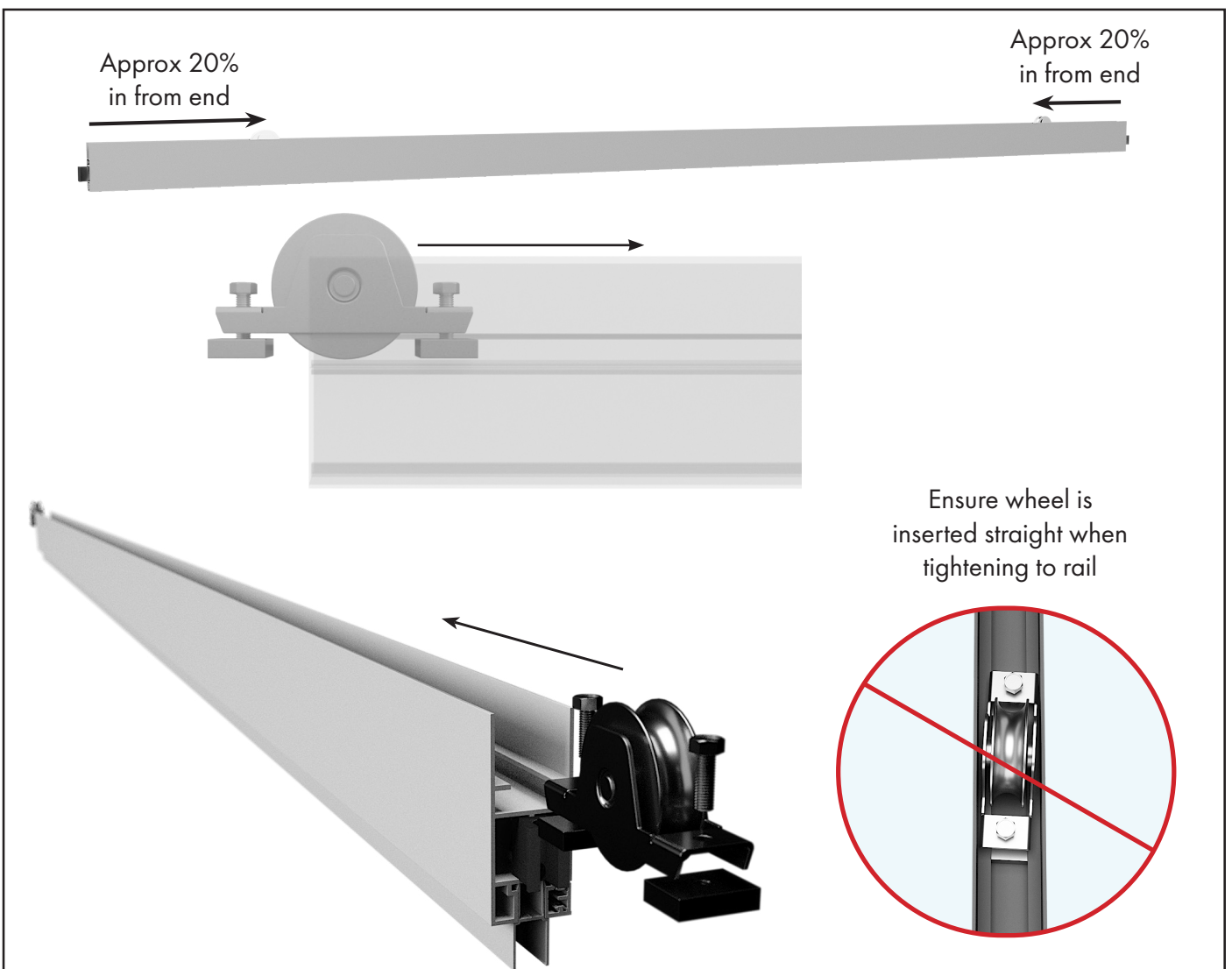

4 Loosely attach wheel clamping sets to both wheels. Then place bottom rail upside down on timber bearers and slide both wheels into position (approx 20% from each end of bottom rail), then tighten bolts.

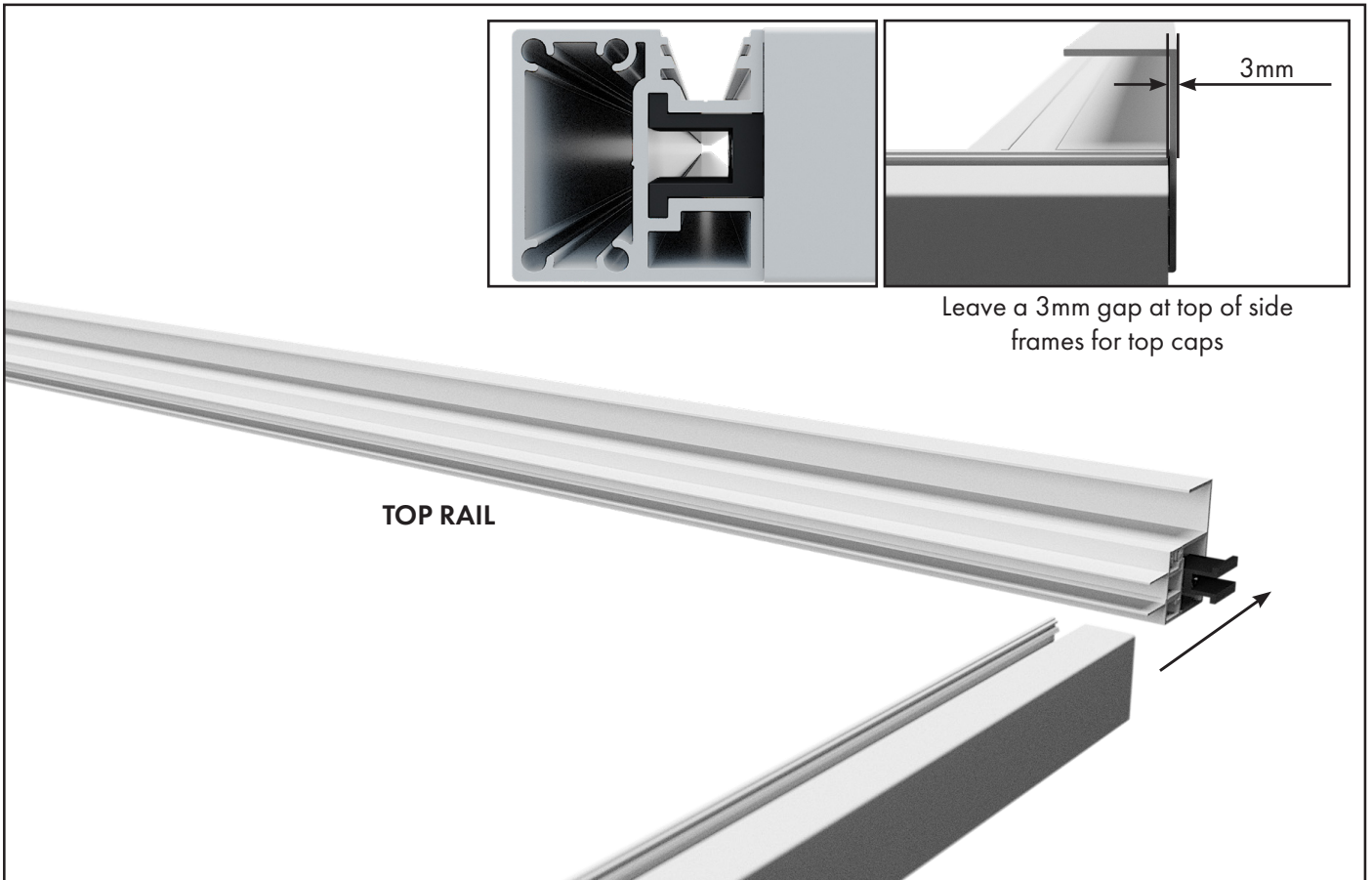

- 5 Slide one Gate Side Frame onto the Top Rail, leaving a 3mm gap at the top for top cap.

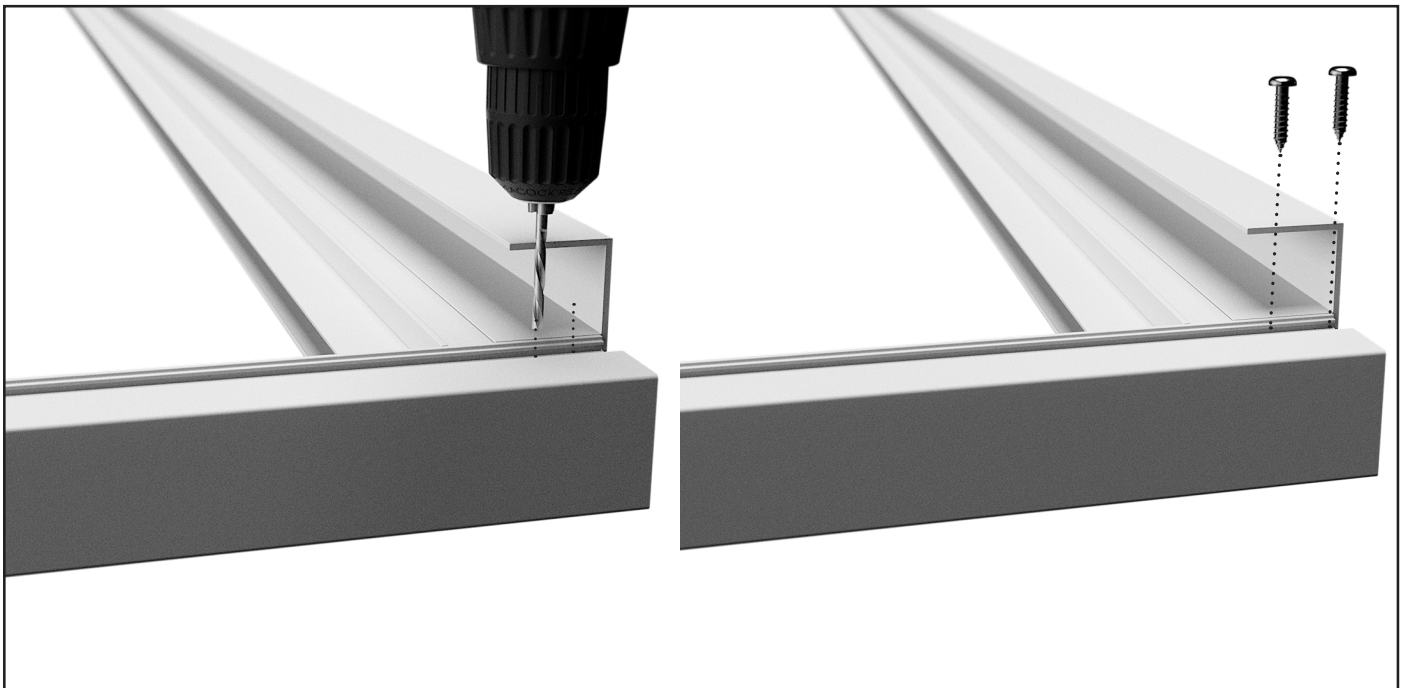

- 6 Pre-drill two 5mm holes through the Gate Side Frame screw channel and Joiner Blocks. Affix two 12G x 25mm long panhead screws per Joiner Block.



- 7 Slide Bottom Rail onto Gate Side Frame, aligning bottom of Bottom Rail with the bottom of the Gate Side Frame (no gap required at bottom).

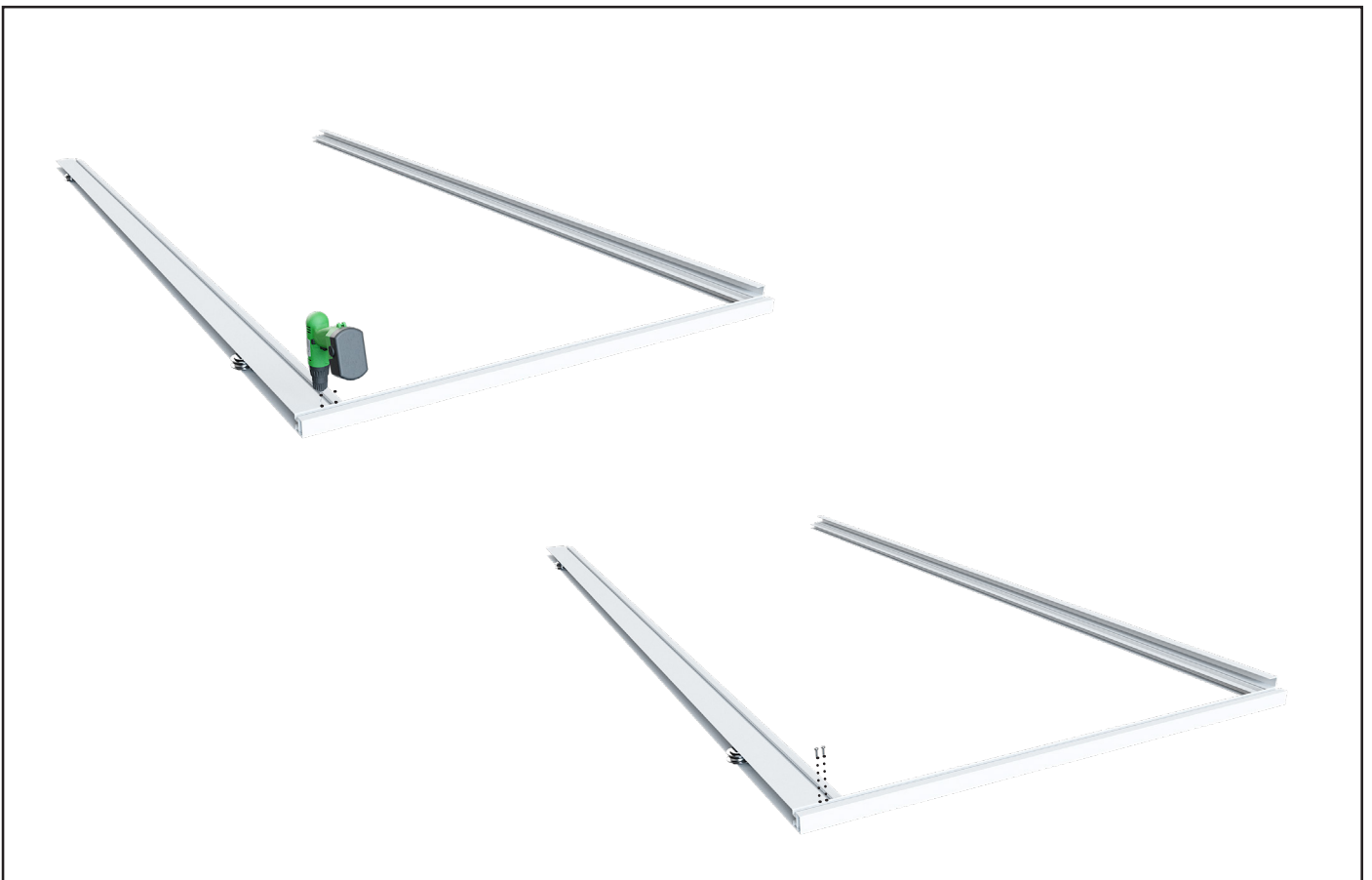

- 8 Drill 2 x holes and secure Gate Side Frame to Bottom Rail through joining block with 2 x screws.

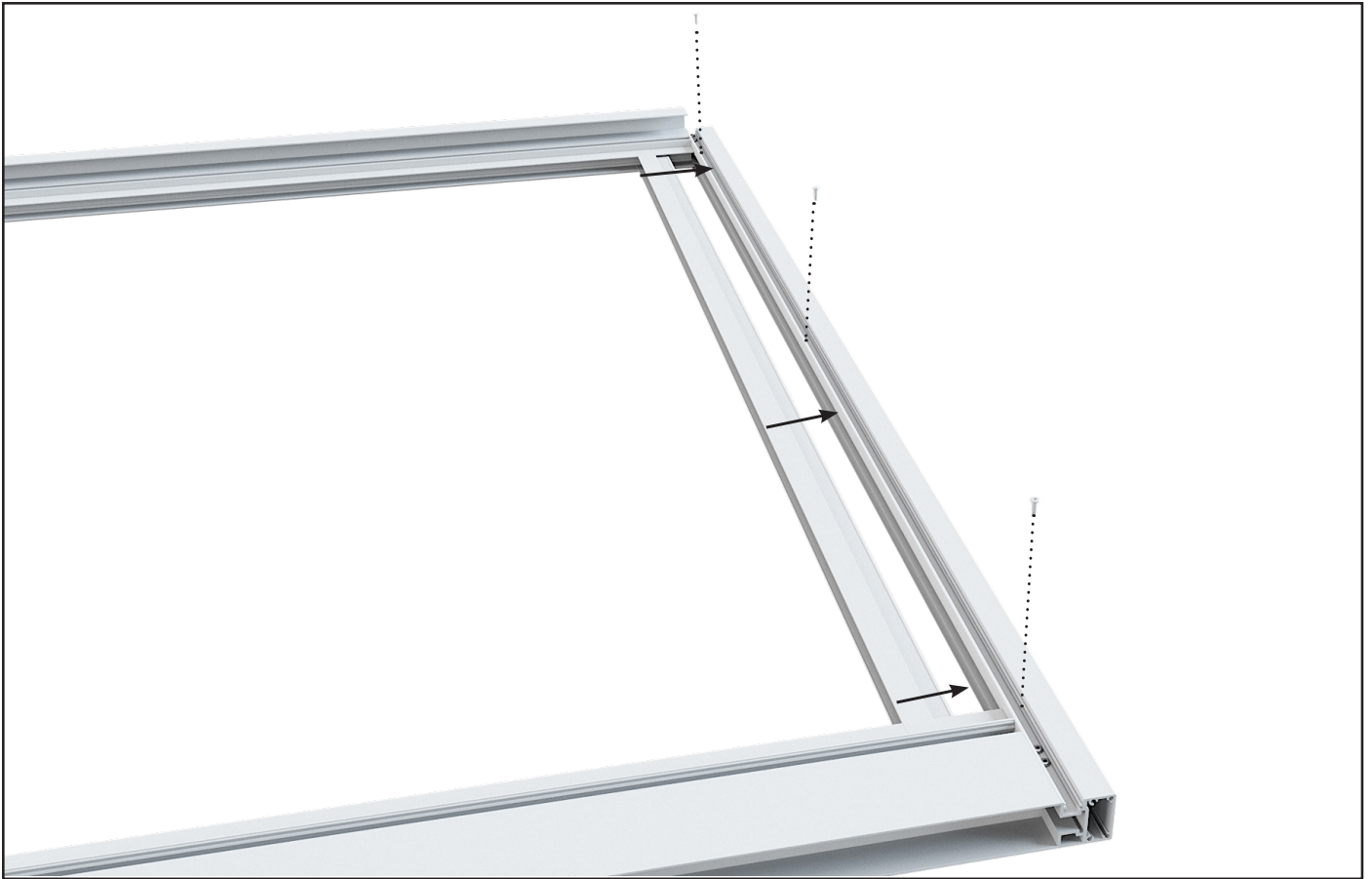

9 Insert Channel Infill for PVC Panels into the Gate Side Frame and secure with 3 screws - one at top, one in middle and one at bottom.



10 Insert first Panel. Push into the Channel Infill.



11 Repeat process with remaining Slats and Slat Spacers. Check gate is square and adjust as necessary.



12 Slide Channel Infill for PVC Panels onto the last Panel on the open ended side and align with the edge of the Top and Bottom Rails.



- 13 Slide Gate Side Frame onto the Channel Infill for PVC Panels and onto the Top Rail Joiner Block. Slide Gate Side Frame slightly beyond the Top Rail to allow Joiner Block to be installed to Bottom Rail.

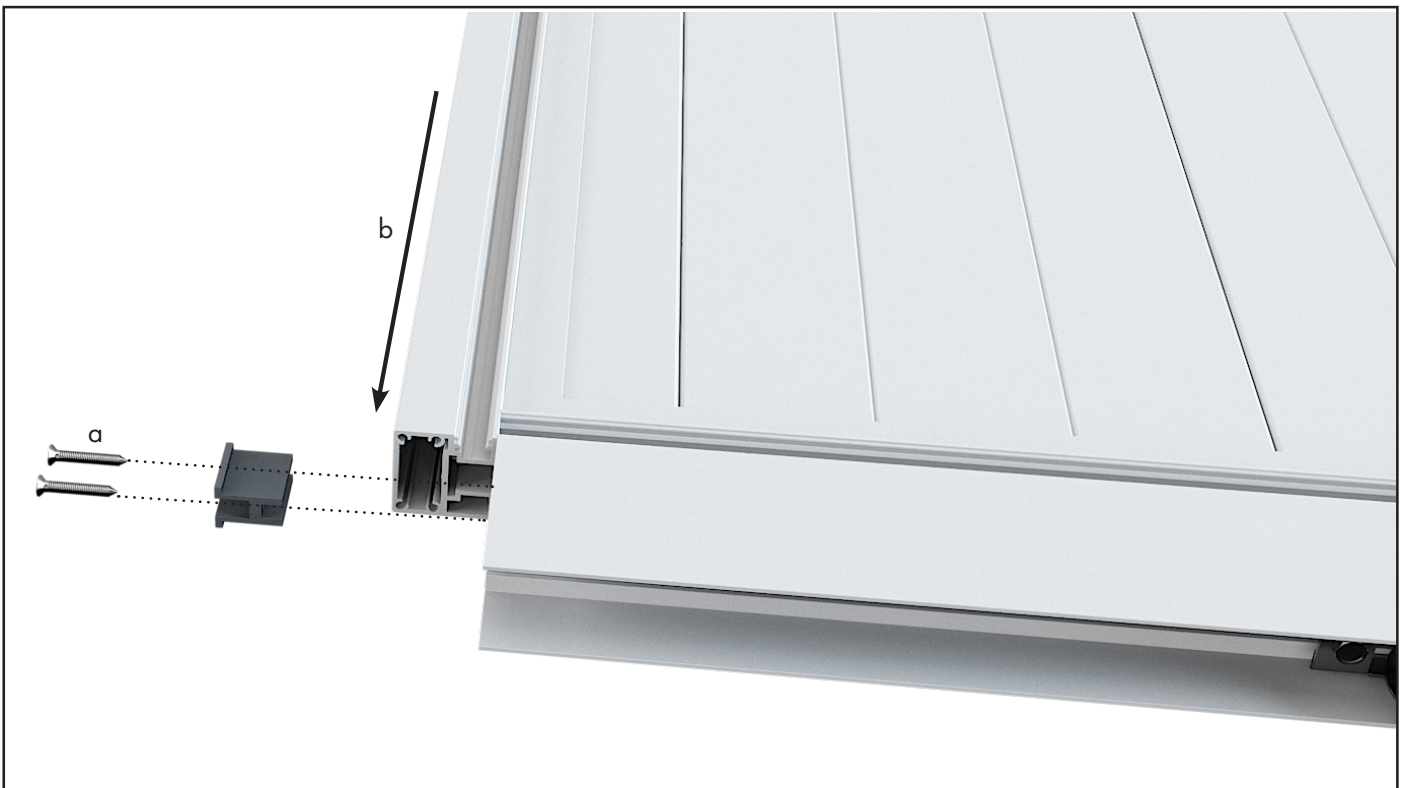

- 14 a) Secure Joiner Block to Bottom Rail with 2 x screws.
b) Slide the Gate Side Frame down so that it is flush with bottom of bottom rail.

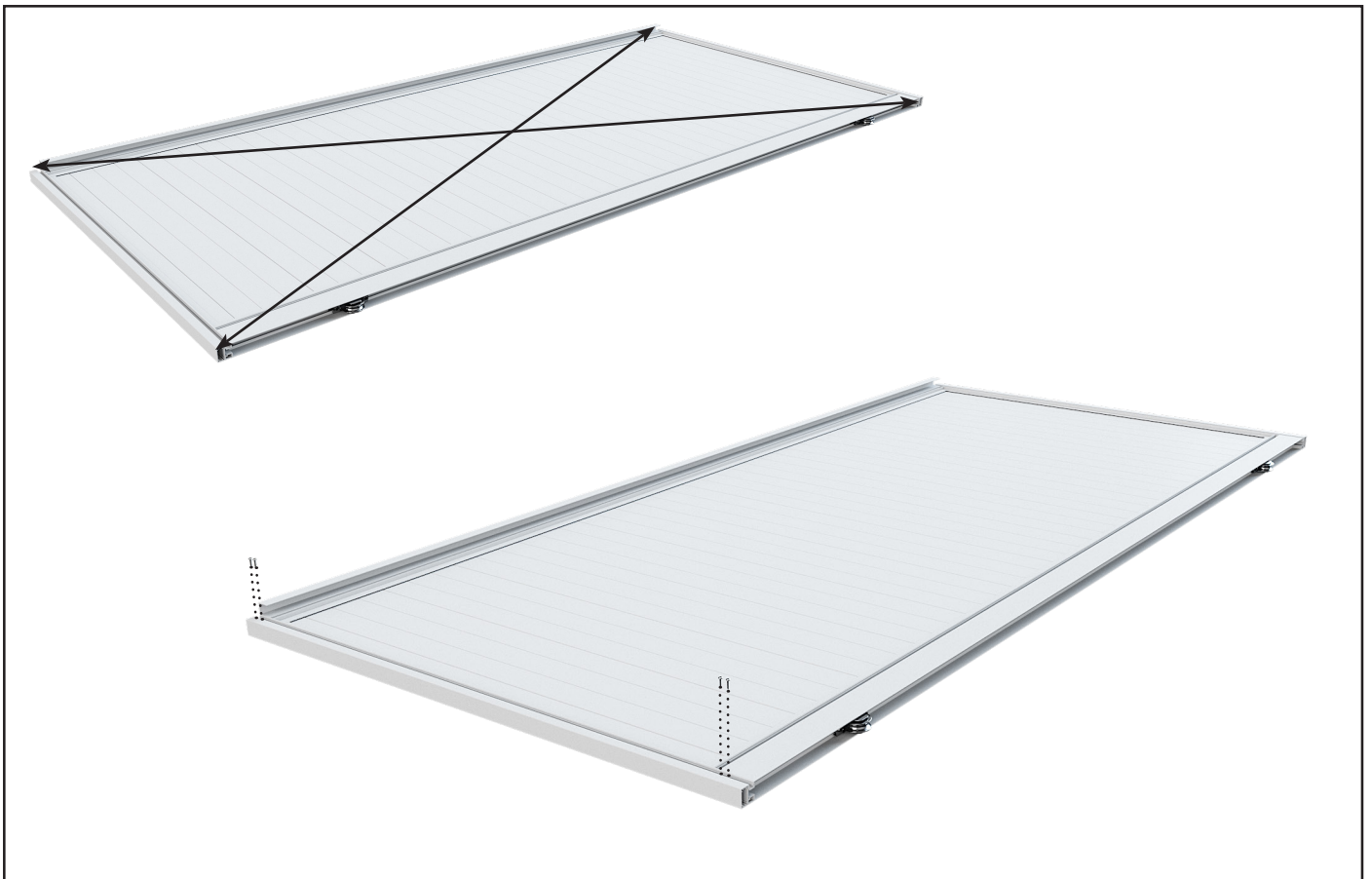

- 15 Check gate is square.
Drill 2 x pilot holes at the top and 2 x pilot holes at the bottom through the Gate Side Frame and into Joiner Blocks on the Top Rail and Bottom Rail.
Secure Gate Side Frame to Top Rail and Bottom Rail with 2 x screws at top and 2 x screws at bottom.



- 16 Affix the Infill for PVC Panels through the Gate Side Frame screw channel using Self-Drilling Wafer Screws



17 Snap on Gate Screw Covers to the Top and Bottom Rail and Gate Side Frames.



18 Slide the Gate Screw Covers down at the bottom of the Gate Side Frames.
Bend the Gate Screw Cover legs as required to achieve a tight insert and push back into position.

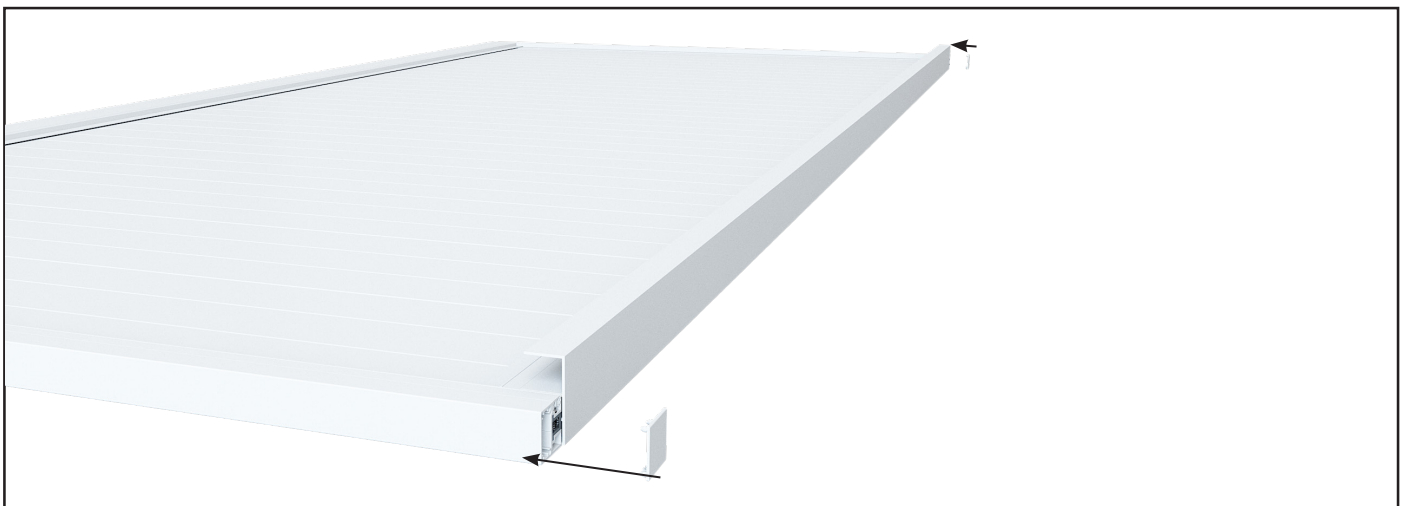

19 Using a rubber mallet, insert the two Top Caps.

U Catch Installation

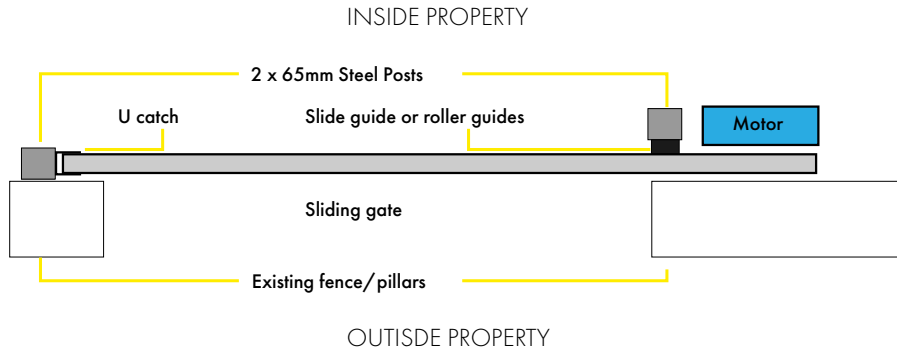

F Catch Installation

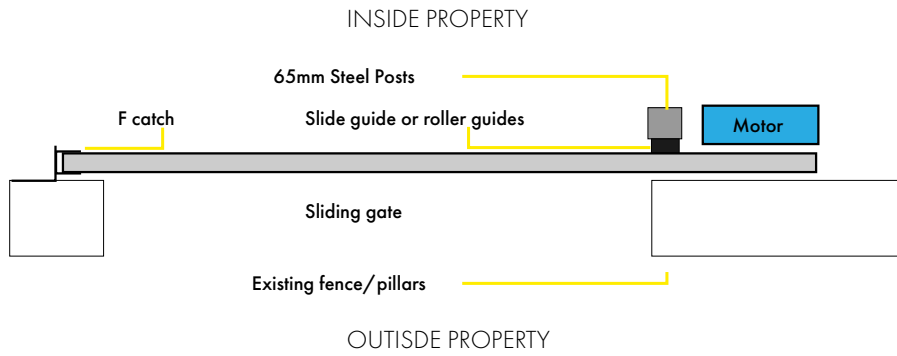

20 Choose from U catch or F catch and install steel posts as required with slide guide or roller guides and gate catch.

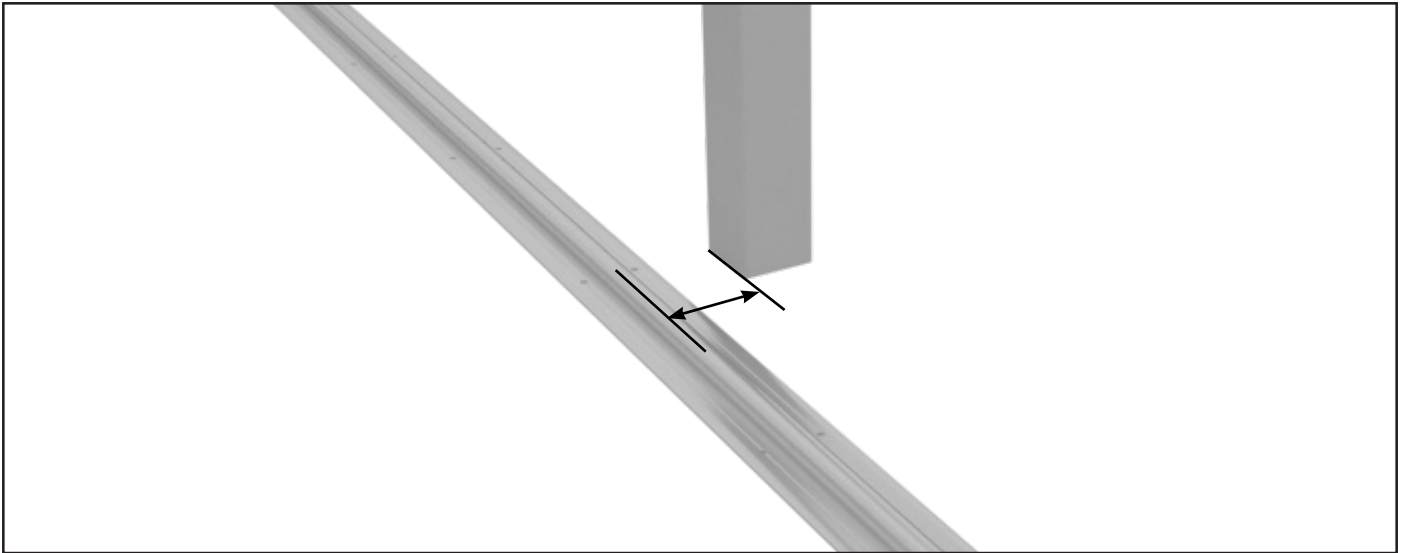

- 21 If using the slide guide, measurement from inside edge of steel post to centre of track is 105mm. If using roller guides, 2 installation options possible:
 Refer to step 25a: measurement from inside edge of steel post to centre of track is 105mm
 Refer to step 25b: measurement from inside edge of steel post to centre of track can be from 100mm to 105mm

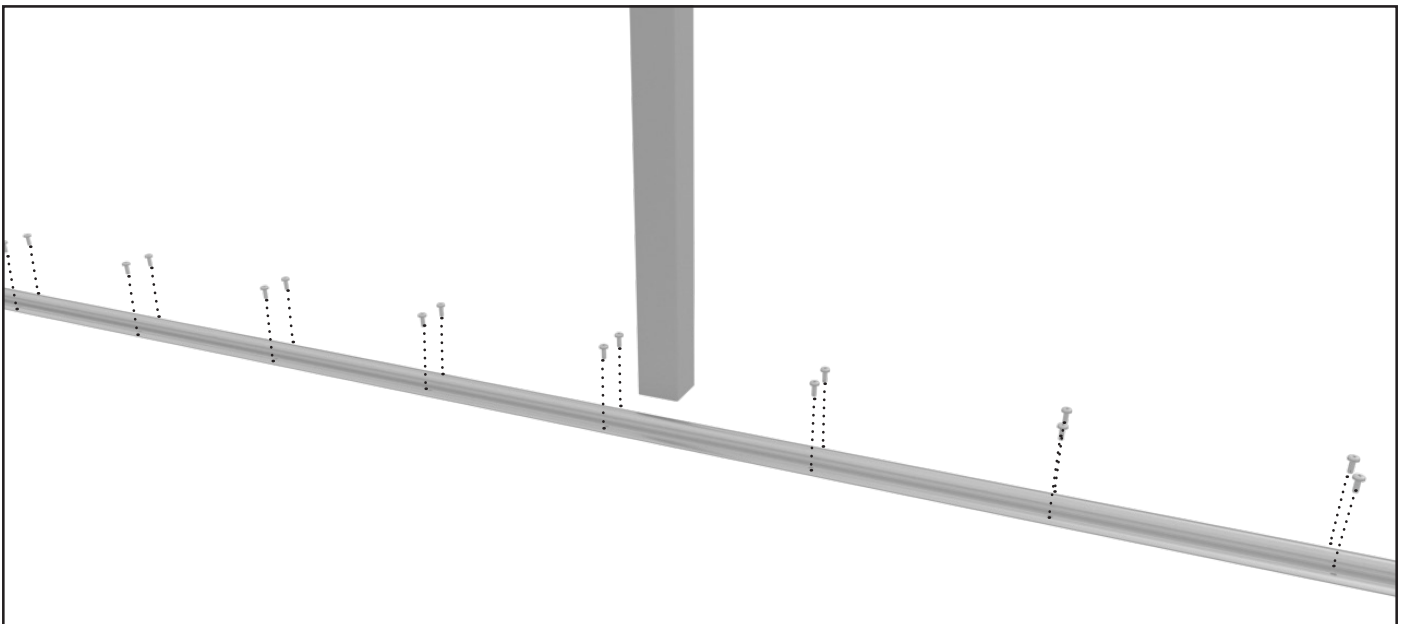

- 22 **TRACK INSTALLATION.**
STEEL TRACK - Using a 6.5mm masonry bit, drill 45mm deep holes in concrete at each pre-drilled slot in track.
ALUMINIUM TRACK - Pre-drill holes in track at 300mm intervals on each side of the raised roller guide using the die line as guide. Using a 6.5mm masonry bit, drill 45mm deep holes in concrete at each pre-drilled hole in track. Thoroughly clean concrete dust from holes and insert track pins into each hole and hammer into position.
NOTE: Take care not to hit raised roller guide

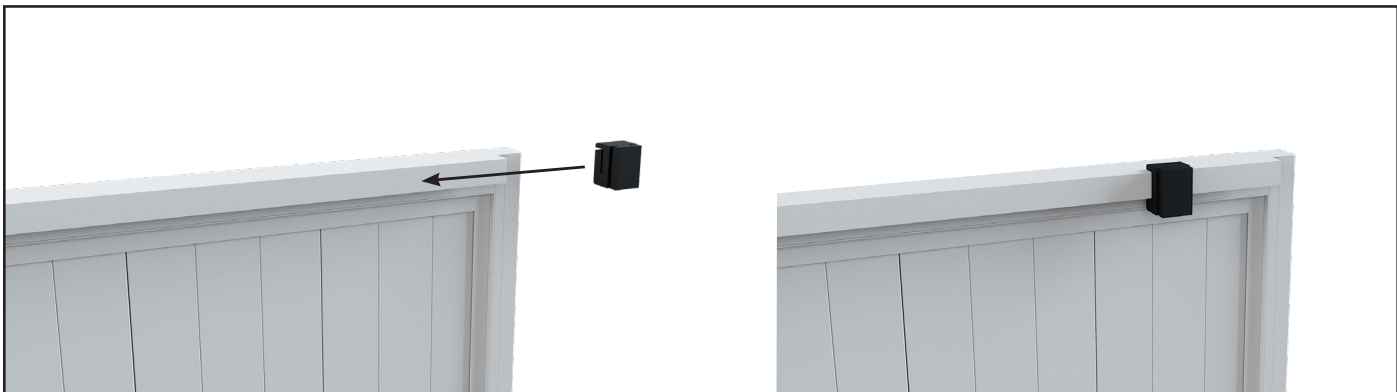

23

IF USING SLIDE GUIDE

Slide the slide guide onto the top rail.



24

IF USING SLIDE GUIDE

Attach slide guide to post. Then, with help from multiple personnel, lift the gate into position.

INSTALL TIP: Generally, the top of the post is installed in-line with the top of the gate. However, if installing on an uneven travelling surface, the top of post may need to be higher than the installed gate height to allow for the up and down movement of the slide guide.

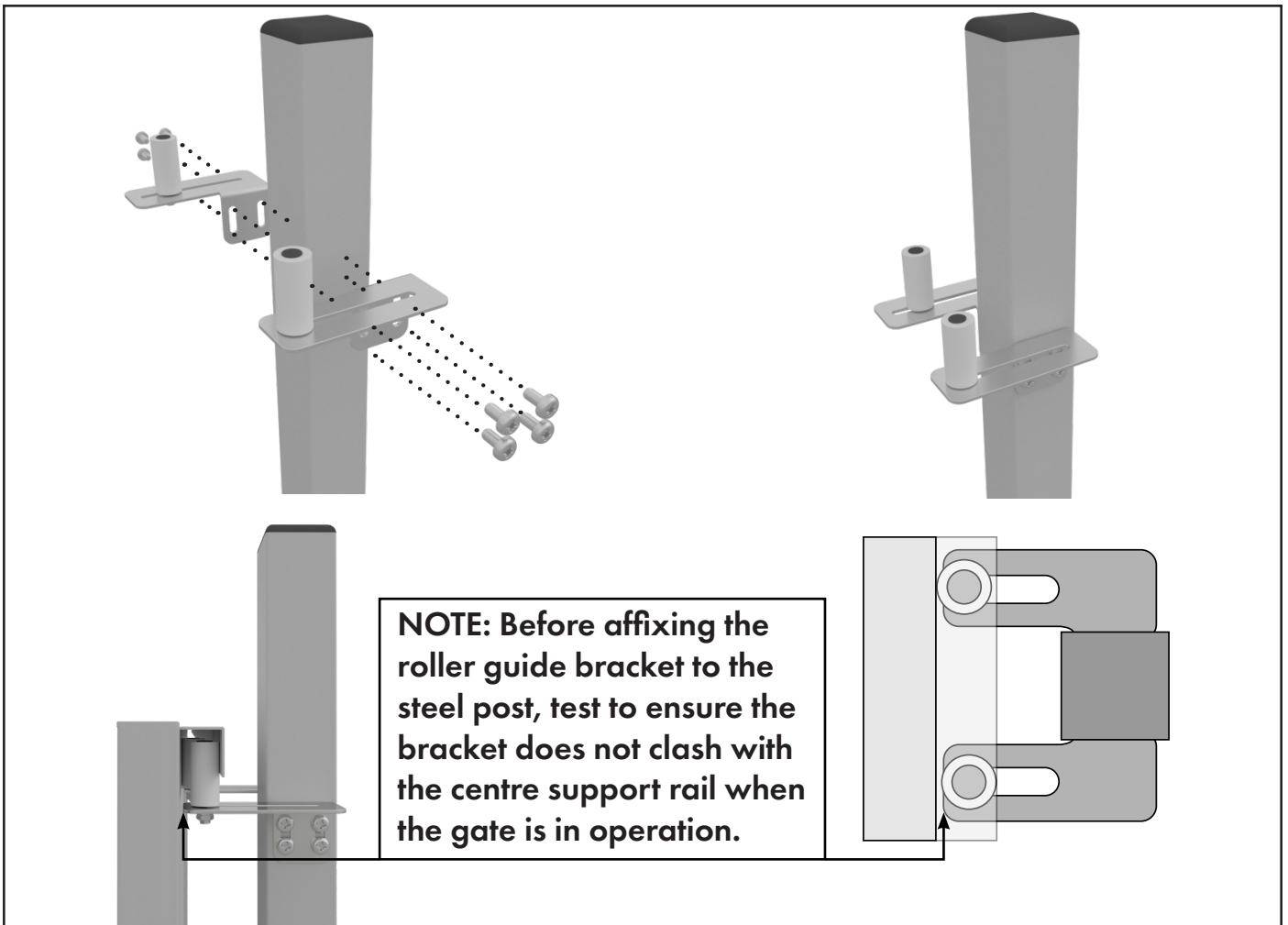

25a IF USING ROLLER GUIDES

Affix roller guides to both side of 65x65mm post. Slide gate into place with both rollers internal of top rail channel. Adjust rollers forwards or backwards and ensure 1x roller is touching each side of inner channel.

NOTE: Roller guides should only be used where deviation in height along gate travel is 15mm or less. If deviation in height is greater than 15mm, use slide guide.

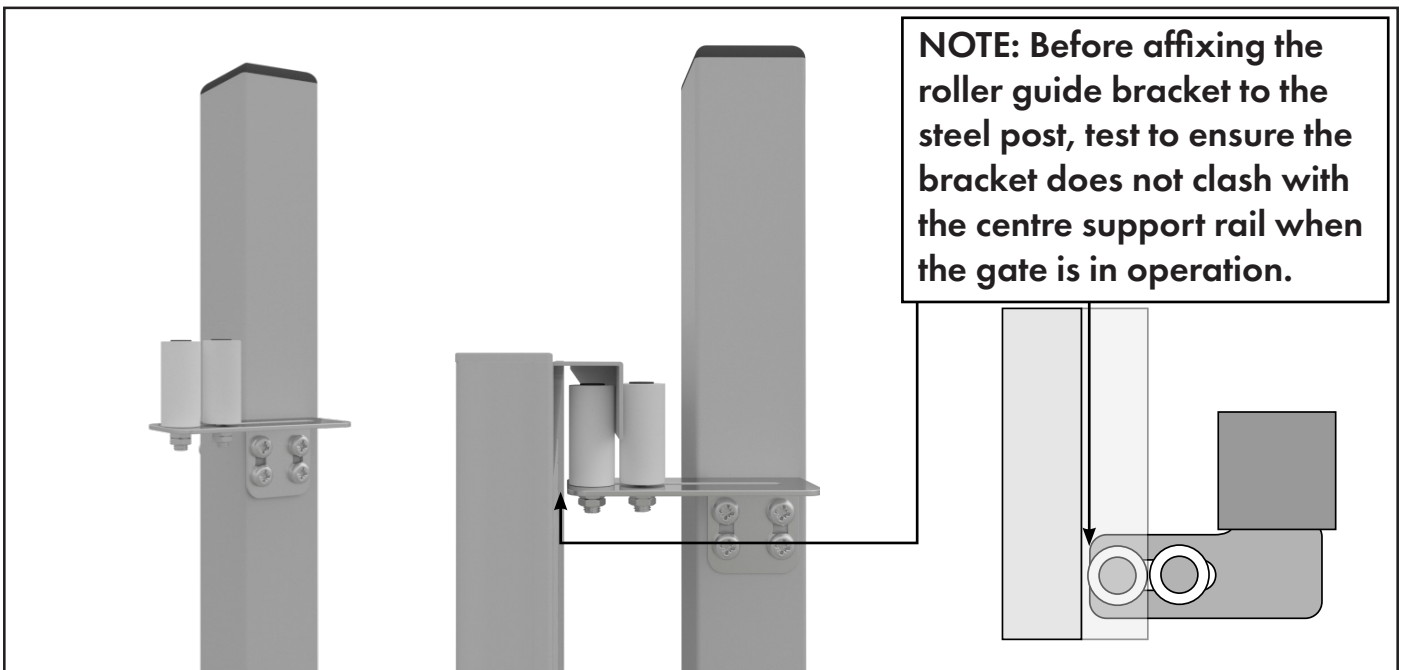

25b Alternative roller guide fixing method: Remove roller from 1x roller guide bracket and fit to other bracket. Affix roller guide bracket to 65x65mm post, then slide gate into place with 1x roller inside and 1x roller outside of top rail channel. Adjust rollers forwards or backwards as needed.

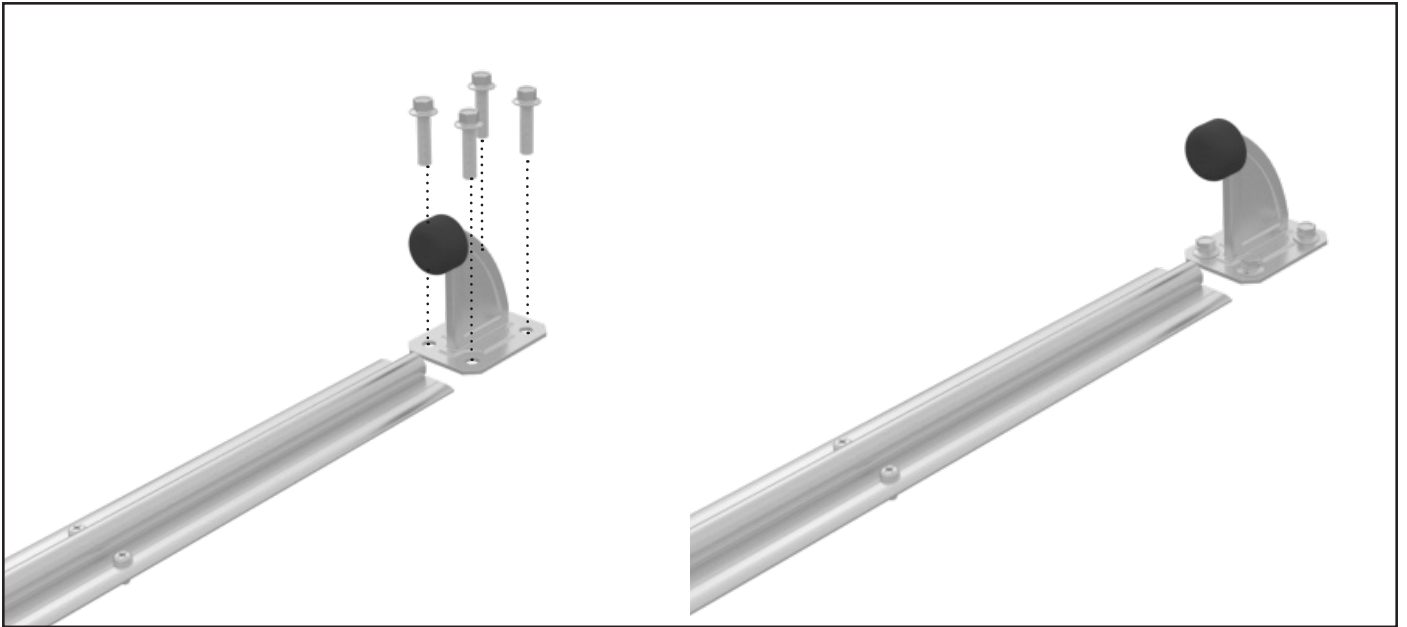

26 Attach the gate stop to concrete floor to allow the gate to stop at a fully opened position (fixings not included).

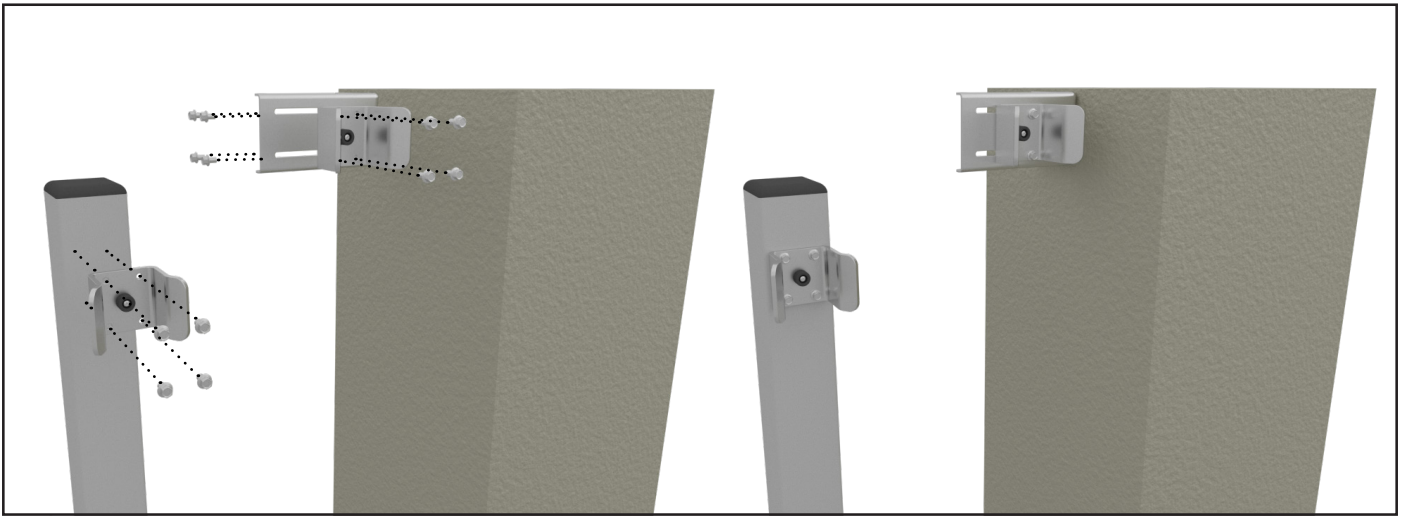

27 Attach the U catch to the 65mm steel post (or affix F catch to existing wall/pillar) to allow the gate to stop at the fully closed position (fixings not included).

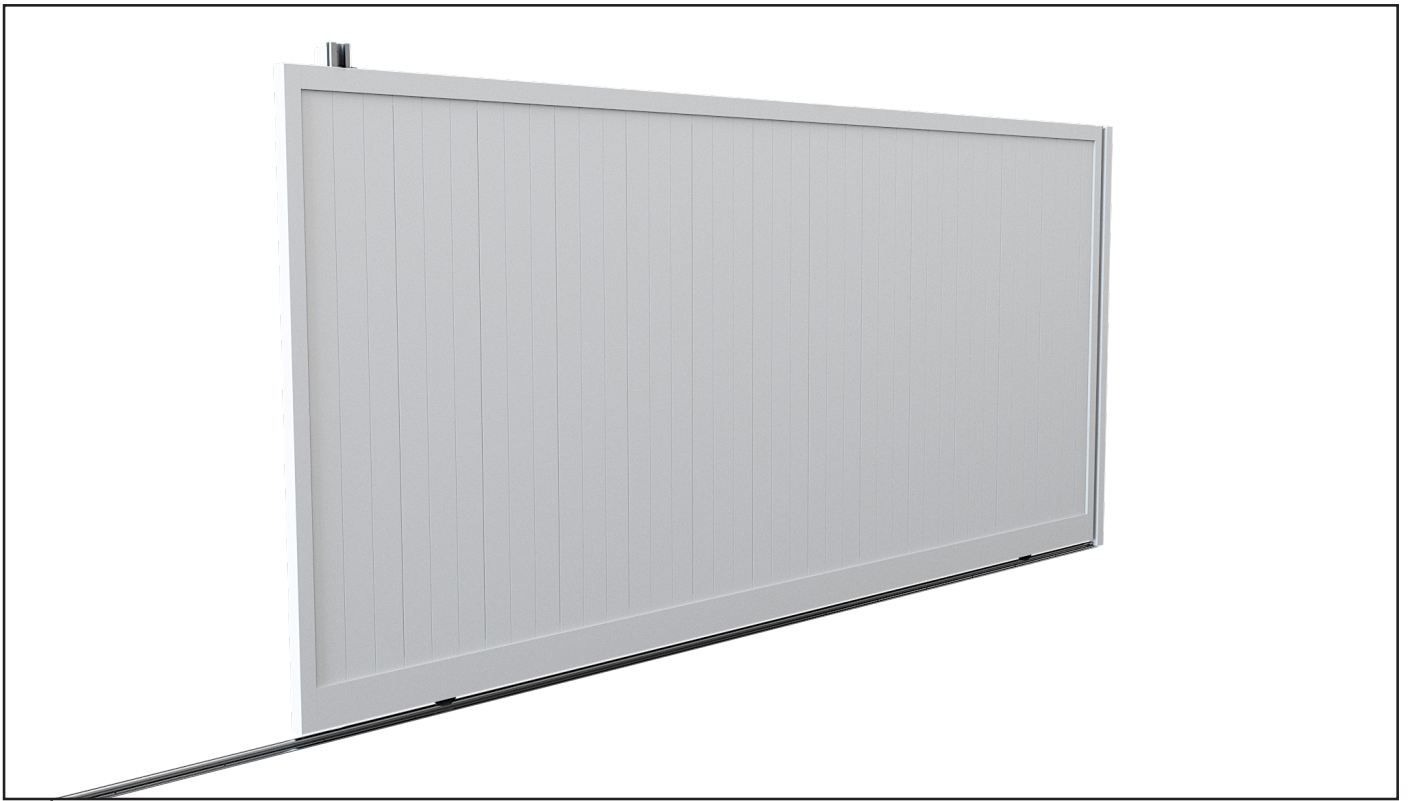

● Gate Fabrication complete.

APPENDIX 1

MOTOR EXTENSION KIT

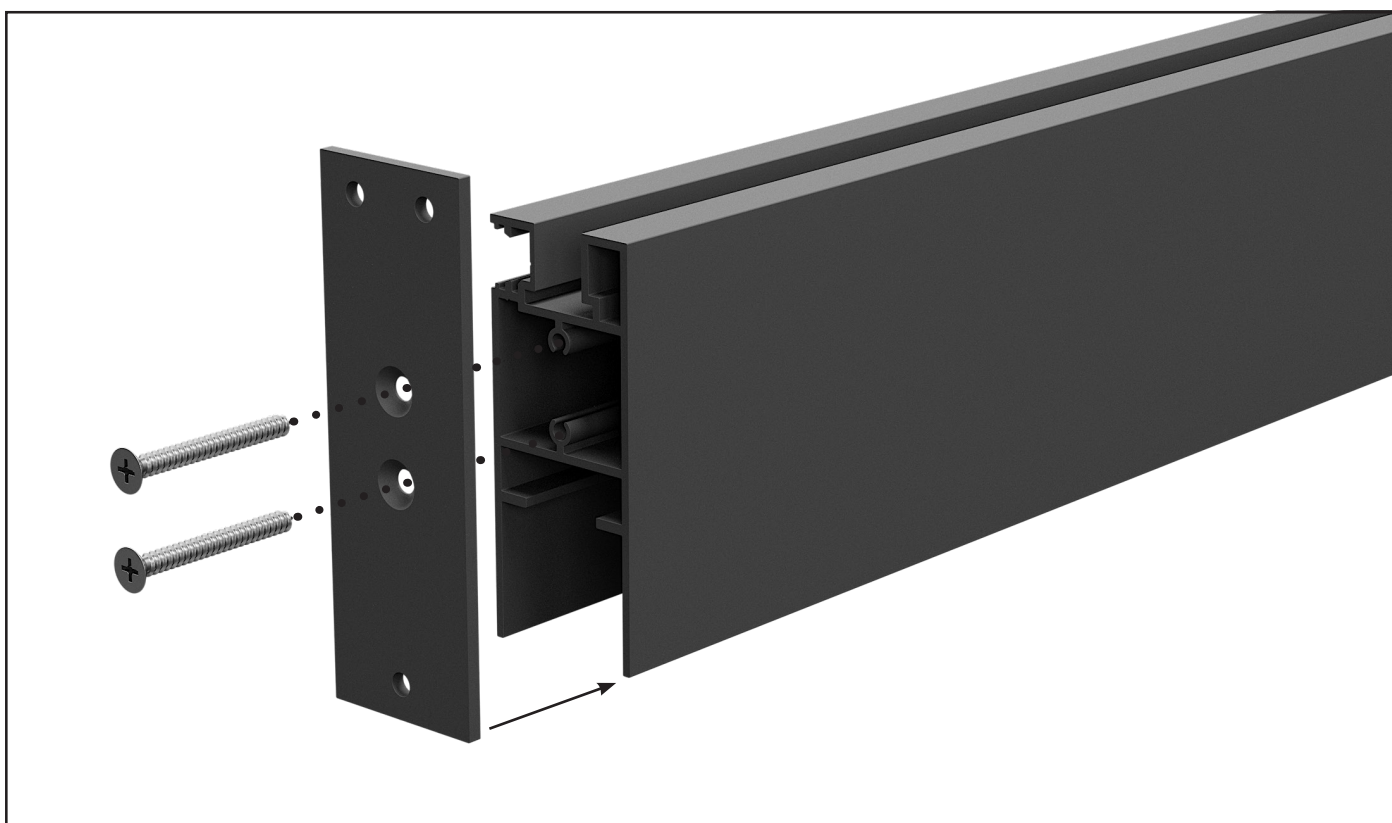
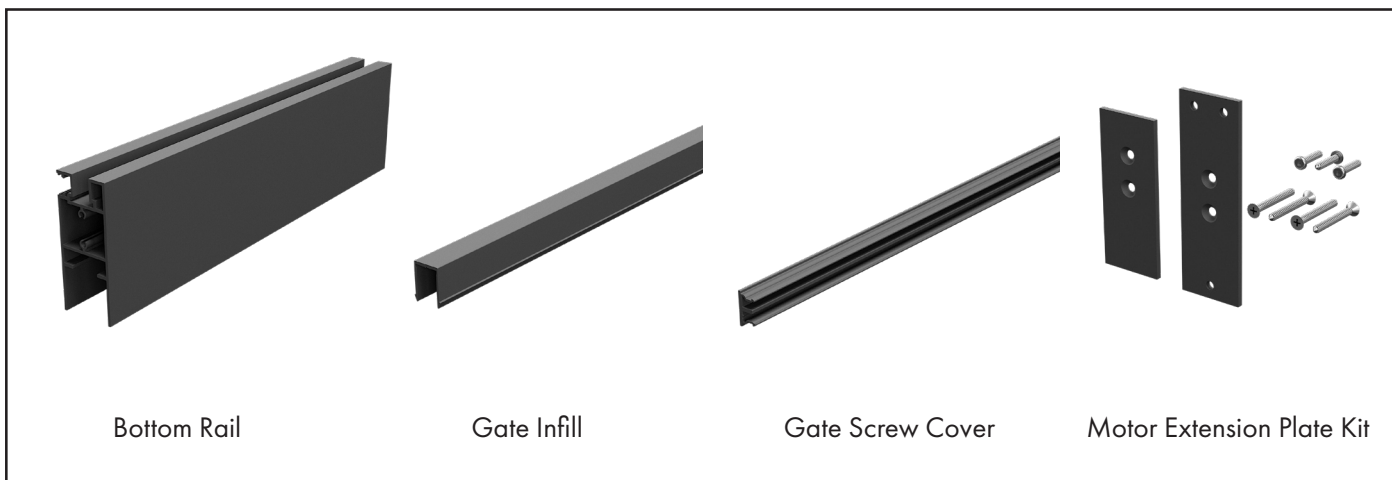

i Attach Fixing Plate to the Bottom Rail using 2 x CSK screws

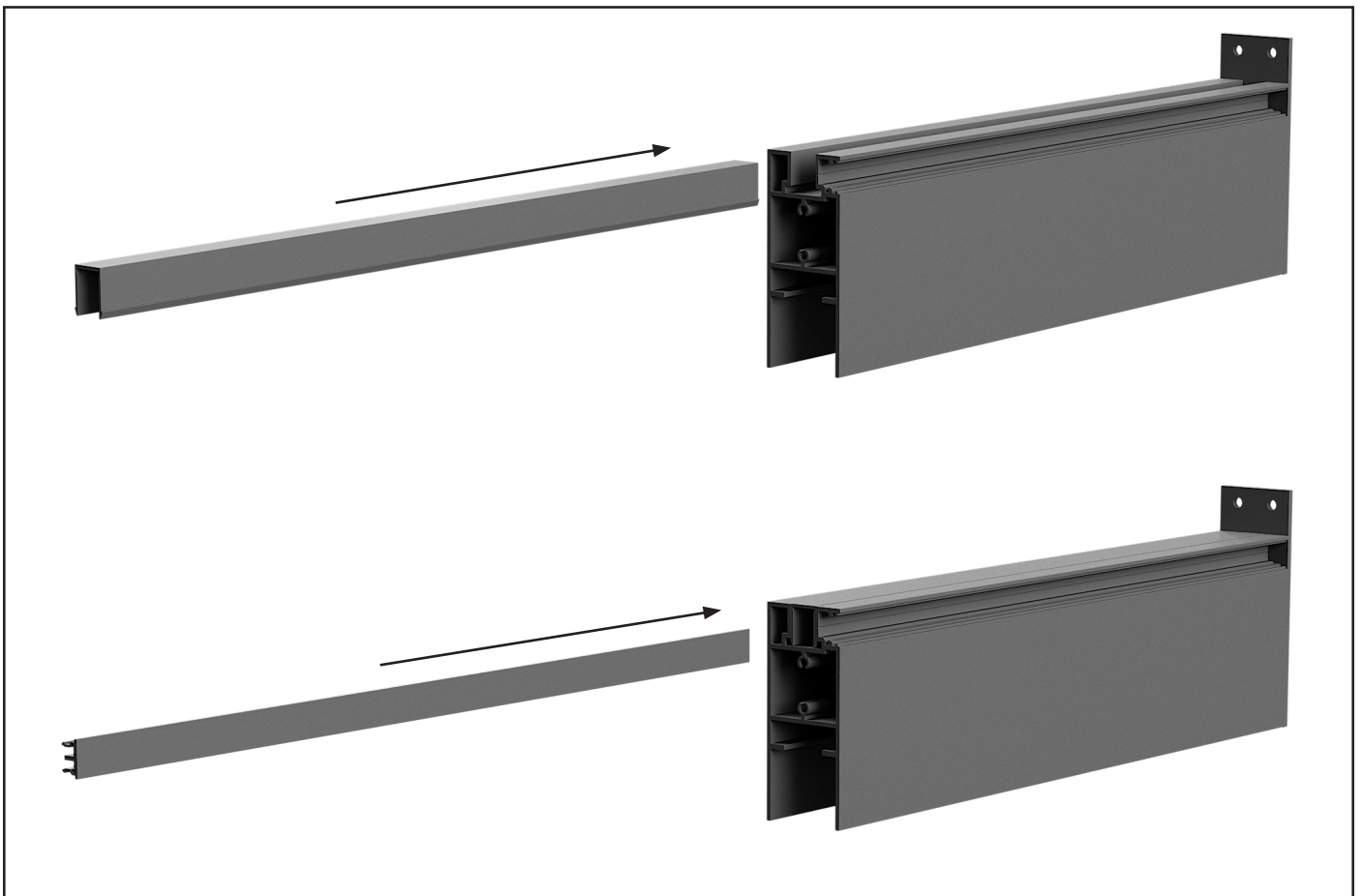

ii Slide the Gate Infill and Gate Screw Cover into the Bottom Rail

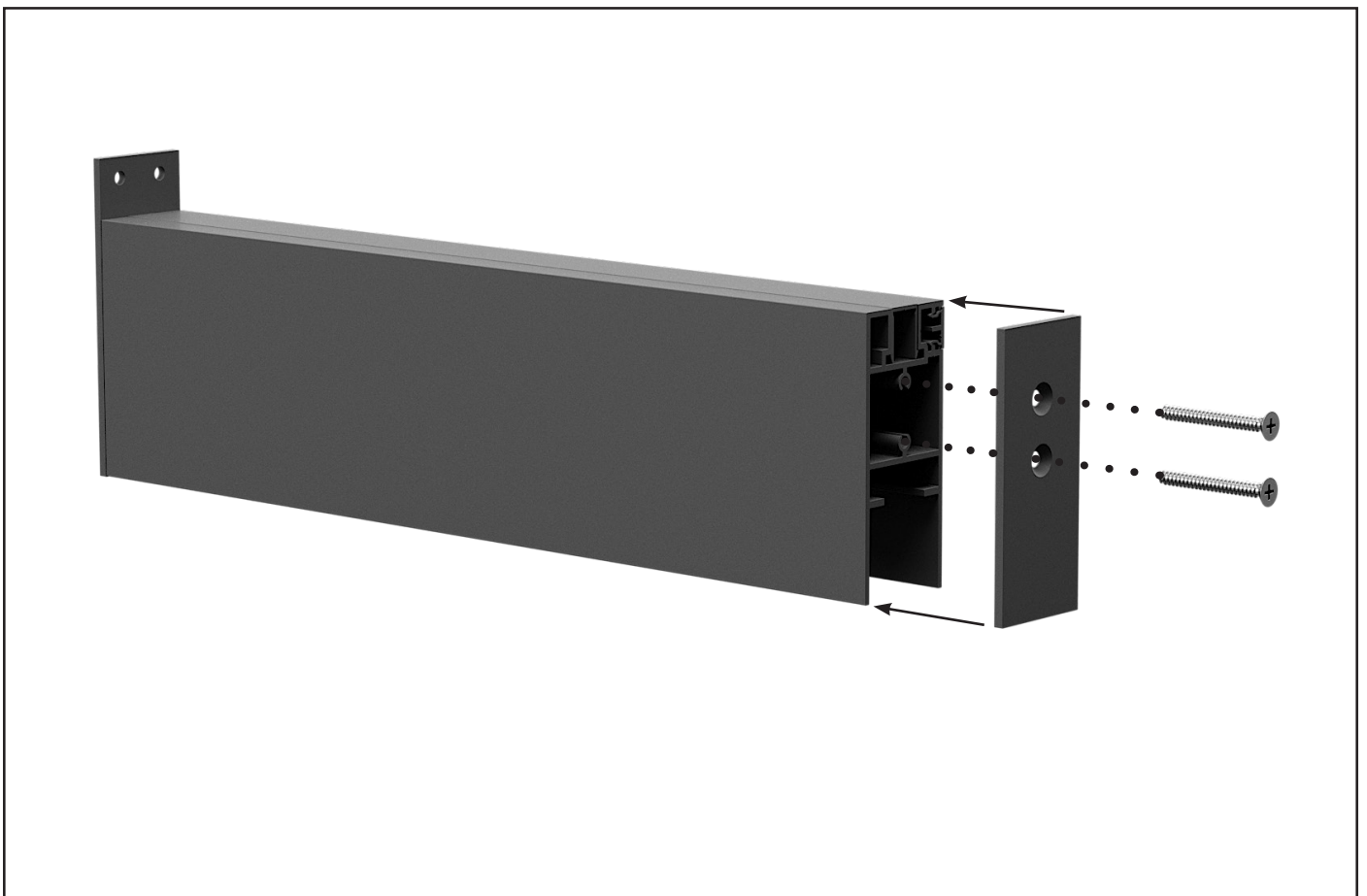

iii Attach the End Plate to the Bottom Rail using 2 x CSK screws

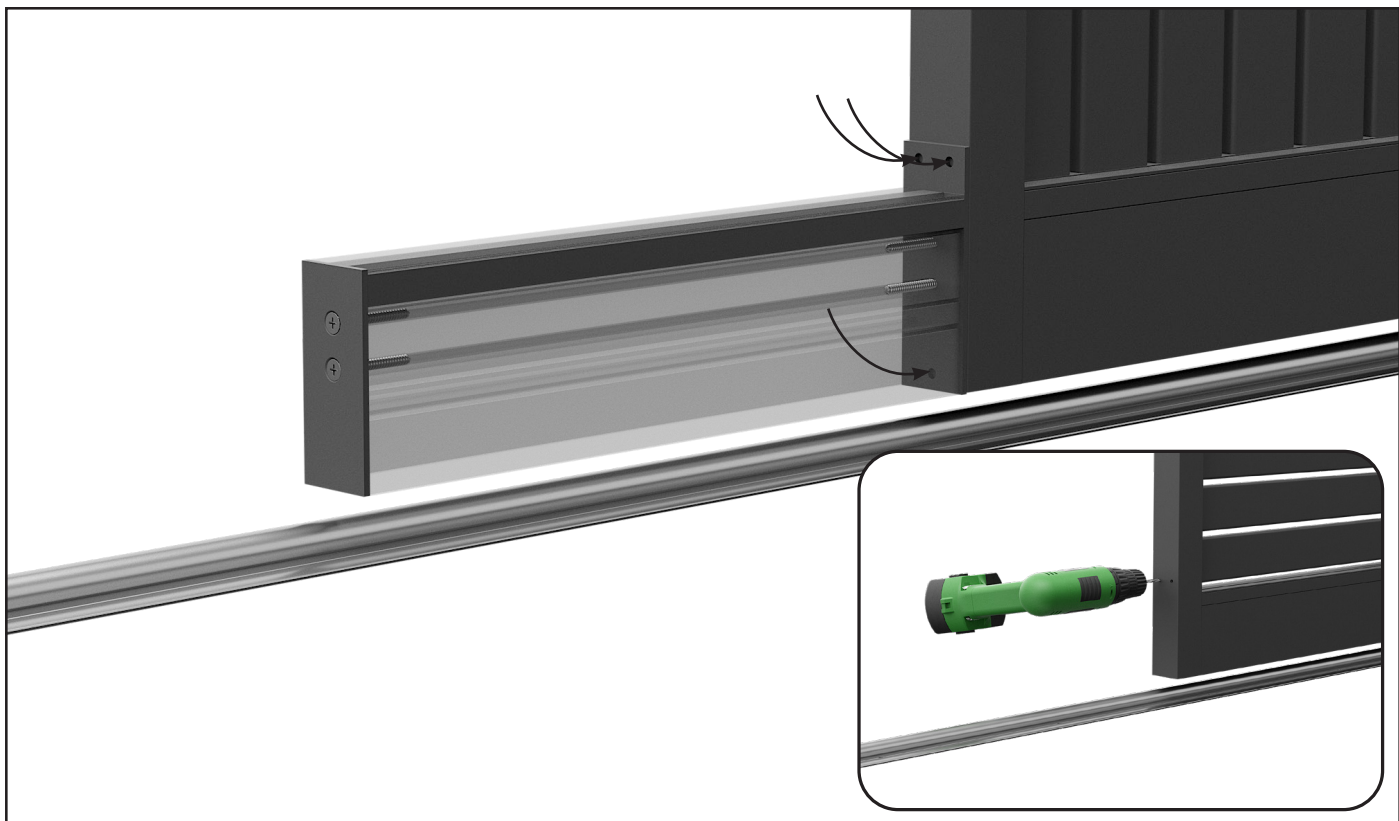

- iv Position Motor Extension against the Gate Side Frame with the Fixing Plate level with the bottom. Mark and predrill 3 x 4mm holes.

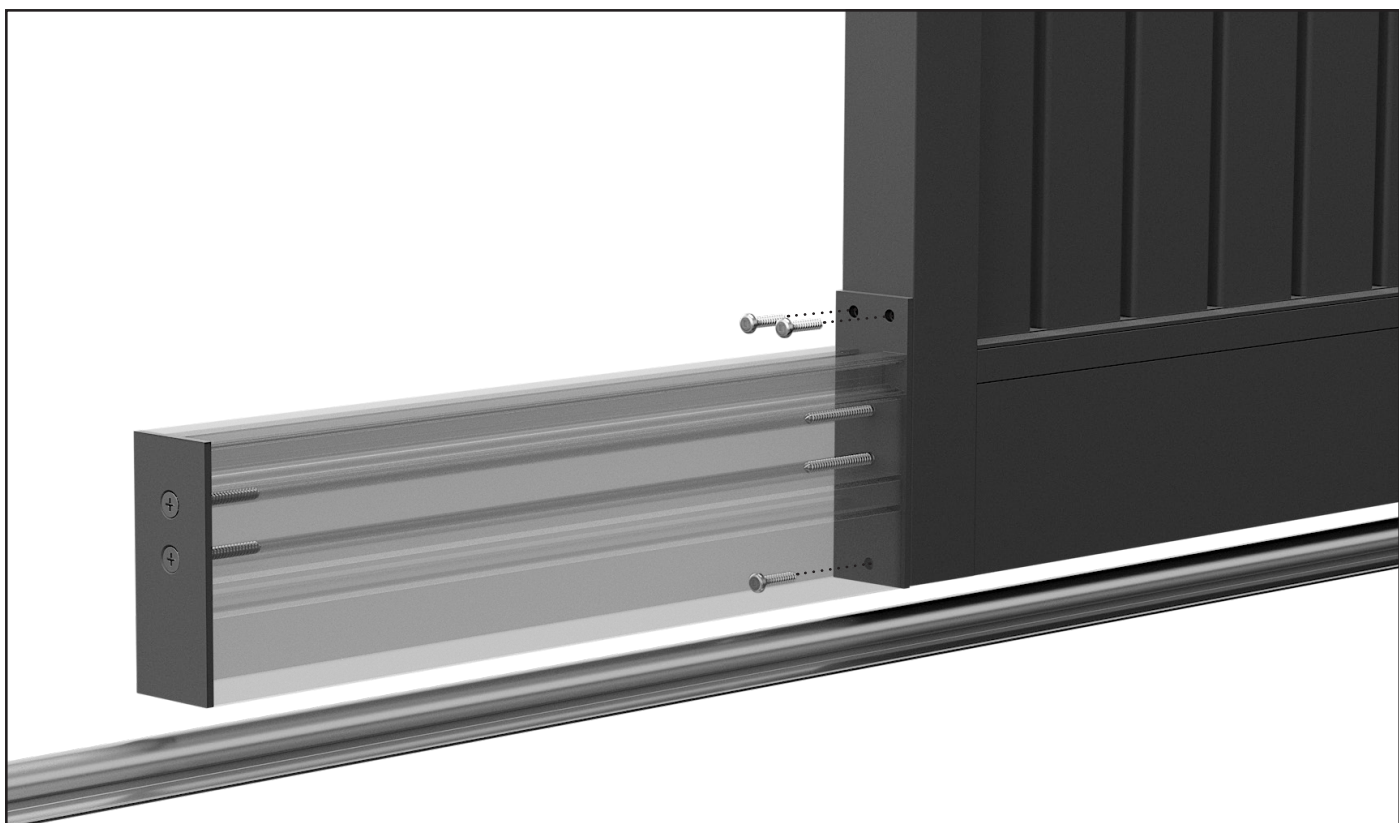

- v Secure the Motor Extension to the Sliding Gate Side Frame with 3 x 25mm Panhead screws.

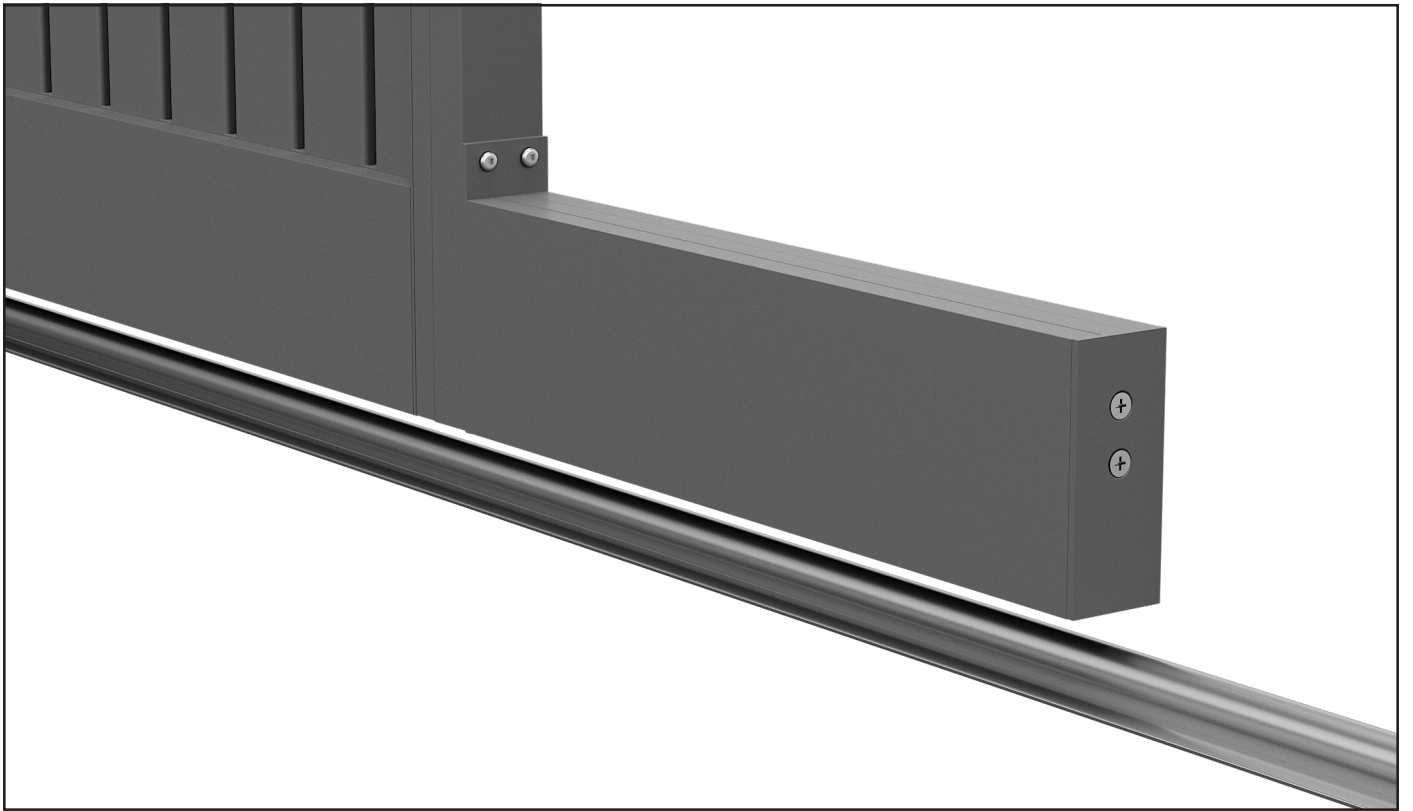

● Completed Motor Extension